

NMEA 2000® / NMEA 0183 Solid State Compass

SSC200

Maretron's SSC200 is a solid state, rate gyro electronic compass that provides better than 1° heading accuracy through $\pm 45^\circ$ of roll and pitch angle, and better than 1° roll and pitch accuracy in static conditions. Each SSC200 is factory calibrated for maximum accuracy. It delivers precise, reliable heading information ten times per second, plus vessel attitude including pitch and roll readings once per second. A micromachined rate gyro is used by advanced stabilization algorithms to provide accurate, stable readings during dynamically changing conditions such as hard turns or rough seas, making it an ideal heading sensor for autopilot applications.

Maretron's SSC200 is certified to the NMEA 2000® network standard and compatible with the NMEA 0183 digital interface standard. It connects directly with any NMEA 2000® network and/or NMEA 0183 listeners to share information with navigational software, chart plotters, autopilots, and dedicated instrument displays – including Maretron's DSM200 graphical display.

The SSC200 can be automatically calibrated for deviation. Its dynamic accuracy is improved with advanced digital filtering of the 3-axis magnetometer, 2-axis accelerometer and rate gyro.

The SSC200 is engineered and manufactured to the highest standards (IEC 60945 *Maritime Navigation and Radiocommunication Equipment*). Its compact waterproof housing will provide years of reliable performance.



Maretron

Leading the way in NMEA 2000® technology

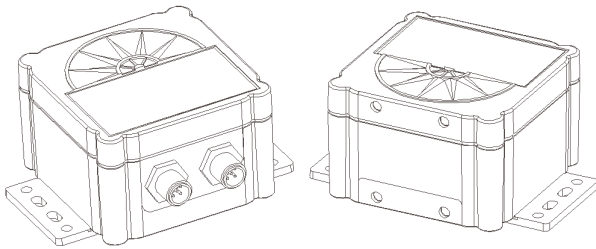
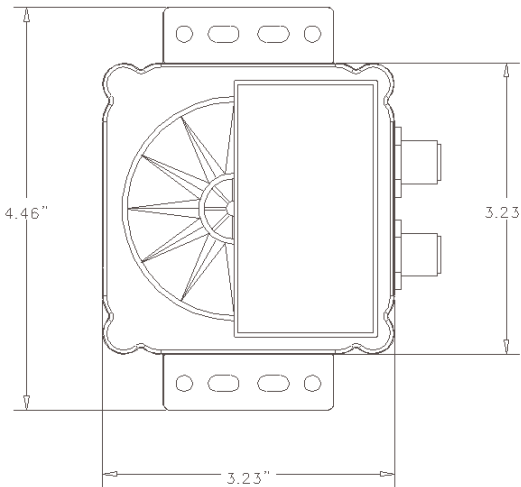
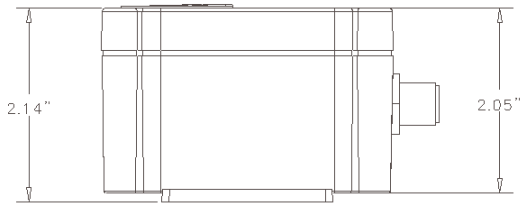

Specifications

Parameter	Value	Comment
Static Heading Accuracy	< 1"	Factory Calibrated ($\pm 45^\circ$ Pitch and Roll)*
Heading Display Resolution	0.1°	With Maretron Display
Settling Time	1 Second	To Static Accuracy After 35°/Second Turn
Heading Update Rate	10 per Second	
Heading Deviation	Yes	Automatic
Alignment Calibration	Yes	In Boat Calibration with Maretron Displays
Pitch and Roll Range	$\pm 80^\circ$	With Maretron Display
Pitch and Roll Accuracy	< 1°	Up to $\pm 45^\circ$ Pitch and Roll*
Pitch and Roll Display Resolution	0.1°	With Maretron Display
Pitch and Roll Update Rate	1 per Second	
Pitch and Roll to Boat Alignment	Yes	In Boat Calibration with Maretron Displays
Rate of Turn Range	0° – 90°/Second	At 0° Pitch and Roll
Rate of Turn Accuracy	1" per Second	
Rate of Turn Update Rate	10 per Second	
NMEA 0183 Standard	Compatible	

* 15°C to 35°C

Certifications

Standard	Comment
NMEA 2000*	Level A
Maritime Navigation and Radiocommunication Equipment & Systems	IEC 60945
FCC and CE mark	Electromagnetic Compatibility

NMEA 2000® Parameter Group Numbers (PGNs)

Description	PGN #	PGN Name
Periodic Data PGNs	127250	Vessel Heading
	127257	Attitude
	127251	Rate of Turn
Response to Request PGNs	126464	PGN List (Transmit and Receive)
	126996	Product Information
	126998	Configuration Information
Protocol PGNs	059397	ISO Acknowledge
	059904	ISO Request
	060416	ISO Transport Protocol, Connection Management
	060160	ISO Transport Protocol, Data Transfer
	060928	ISO Address Claim
	065240	ISO Address Command
	126208	NMEA

NMEA 0183 Sentences

Sentence	Description
HDG	Heading, Deviation, and Variation
HDM	Heading, Magnetic
HDT	Heading, True
ROT	Rate of Turn
RMC (receive)	Recommended Minimum Specific GNSS Data (variation)
VTG (receive)	Course Over Ground and Ground Speed (variation)

Electrical

Parameter	Value	Comment
Operating Voltage	9 to 16 Volts	DC Voltage
Power Consumption	< 150mA	Average Current Drain
Load Equivalence Number (LEN)	3	NMEA 2000* Spec. (1 LEN = 50mA)
Reverse Battery Protection	Yes	Indefinitely
Load Dump Protection	Yes	Energy Rated Per SAE J1113

Mechanical

Parameter	Value	Comment
Size	4.46" x 3.23" x 2.14"	Including Flanges for Mounting
Weight	7 Oz.	
Mounting	Deck or Bulkhead	

Environmental

Parameter	Value
IEC 60945 Classification	Exposed
Degree of Protection	IP67
Operating Temperature	-25°C to 55°C
Storage Temperature	-40°C to 70°C
Relative Humidity	93%RH @ 40°C per IEC 60945-8.2
Vibration	2-13.2Hz @ ± 1 mm, 13.2-100Hz @ 7m/s ² per IEC 60945-8.7
Rain and Spray	12.5mm Nozzle @ 100liters/min from 3m for 30min per IEC 60945-8.8
Solar Radiation	Ultraviolet B, A, Visible, and Infrared per IEC 60945-8.10
Corrosion (Salt Mist)	4 times /days @ 40°C, 95%RH after 2 hour Salt Spray Per IEC 60945-8.12
Electromagnetic Emission	Conducted and Radiated Emission per IEC 60945-9
Electromagnetic Immunity	Conducted, Radiated, Supply, and ESD per IEC 60945-10
Safety Precautions	Dangerous Voltage, Electromagnetic Radio Frequency per IEC 60945-12

Maretron

9034 N. 23rd Avenue
Suite 13
Phoenix, AZ 85021

Phone: 866-550-9100

Fax: 602-861-1777

Email: sales@maretron.com

Web: www.maretron.com

Maretron

Leading the way in NMEA 2000® technology